



Assembly instructions MA027 Special Fork plug

 The use of parts and tools other than those stated by MC® or disregarding these preparation instructions, can have an effect on safety and quality. Therefore, technical data cannot be guaranteed.

 For protection against electrical shock, parts must be isolated from the power supply while being assembled or disassembled.

Technical data: $I_n = 150 \text{ A max. with } 100 \text{ mm}^2 \text{ cable}$
 $U_n = 25 \text{ VAC} / 60 \text{ VDC max.}$

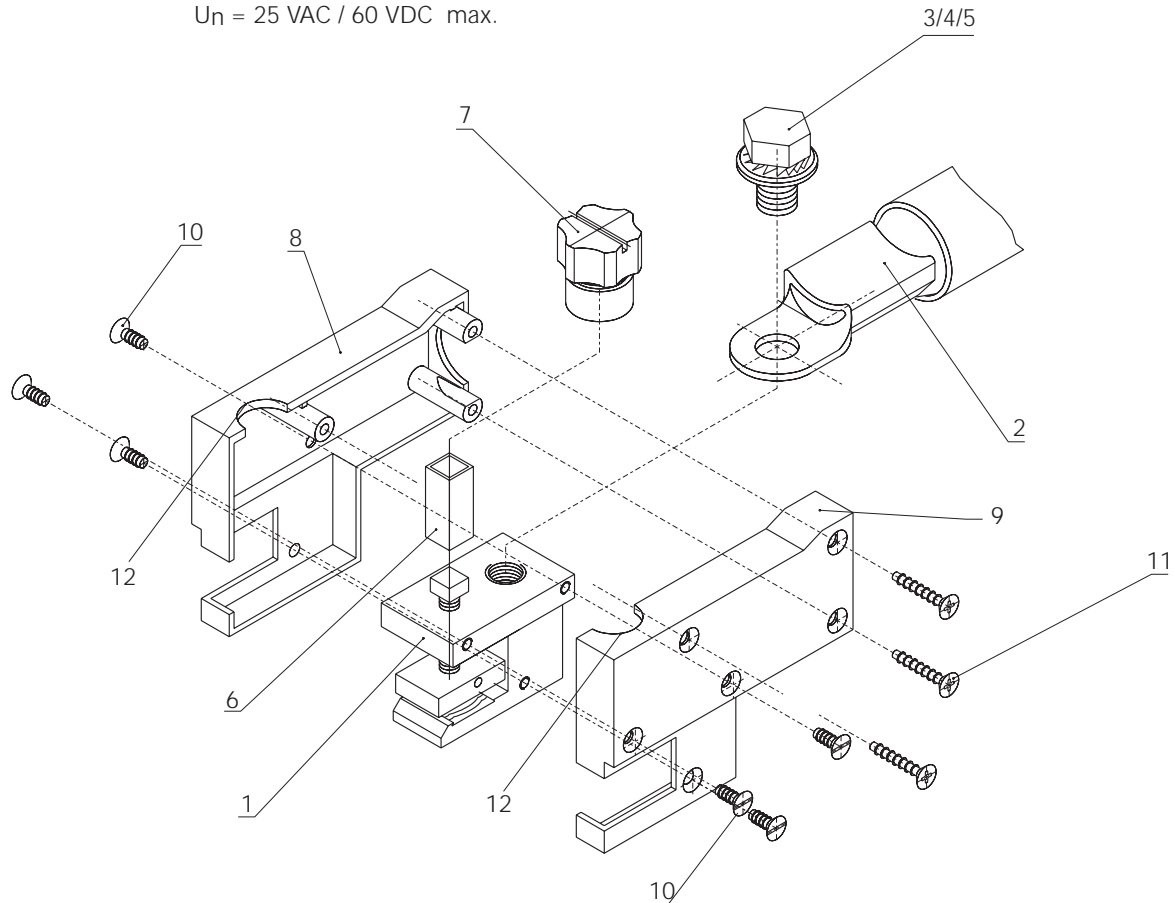

1. Tools required



Torque spanner 19 mm, 16 Nm

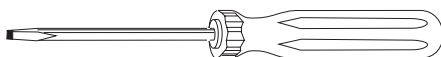

Screwdriver size 3

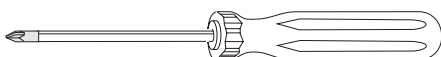

Screwdriver size 2

2. Assembly

- A. Clamp body of fork (1) in vice
- B. Fix cable lug (2) with crimped-on cable in place with screw (3), washer (4) and serrated locking washer (5). (Cable lug not included in delivery). Max. tightening torque 16 Nm. Position the cable lug in such a way that the cable runs towards the back in an axial direction.
- C. Fit coupling piece (6) and knob (7).
- D. Fix left and right insulation (8+9) with PA screws (10), taking care that the rounded parts (12) of the insulation fit into the slot on the knob.
- E. Screw in PT screws (11).